

# HALL EFFECT CT 50A HCT016

## Description

The Hall effect current sensor provides strong electrical isolation between the output of the sensor and the current carrying conductor. The output of the sensor reflects the real wave shape of DC, AC and pulsed currents of the primary circuit.



## General Specifications

Input Current:	+/- 50A <sub>dc</sub>
Measurement Output:	+/- 5V <sub>dc</sub>
Response time T <sub>90</sub> :	≤30μS
Accuracy	1%
Linearity error:	< 0.4%
Offset voltage	±20mV
Hysteresis error	±10mV
Output impedance:	100Ω
Minimum output load:	8k2Ω
recommended output load:	≥15kΩ
Zero adjustment:	± 2%
Span adjustment:	± 20%
Temperature drift	≤250ppm/°C
Current consumption	≤25mA
Power Supply:	± 15V <sub>dc</sub> ± 5% regulated
Isolation	3 kV <sub>rms</sub> / 50Hz / min
Overload:	1000A
Operating temperature range	-10°C~+80°C
Storage temperature range	-25°C~85°C
Fire retardancy	UL94-V0

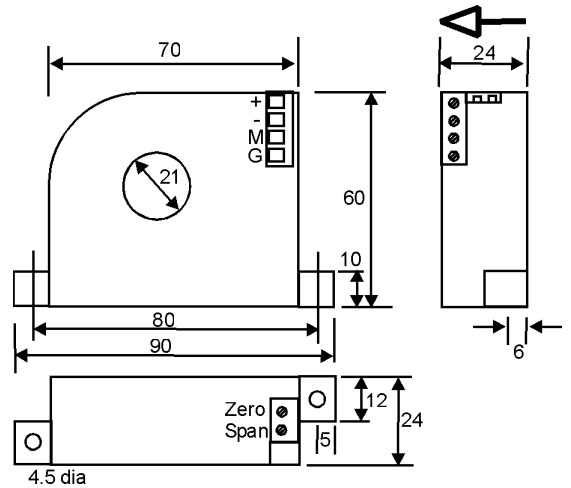

## Application

The HCT016 is designed for use with the DCT247. The DCT247 is a din mounted signal conditioning module for monitoring of DC and true RMS AC currents and provides a standard process signal output or relay contact.

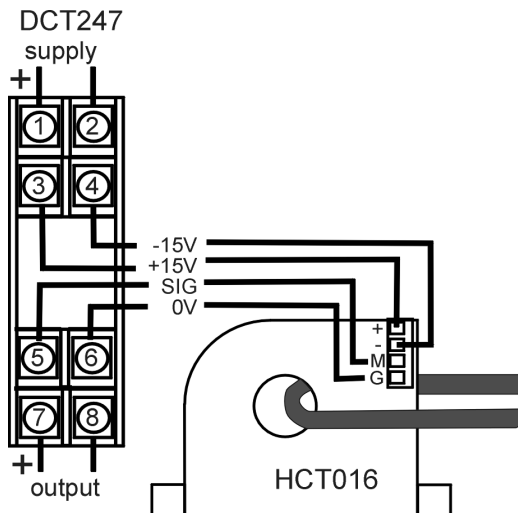

In the interest of development and improvement, APCS reserve the right to amend, without notice, details contained in this publication. APCS will accept no legal liability for any errors, omissions or amendments.