

Analog to Potentiometer v1 ATP168

DESCRIPTION

The ATP168 is an isolating signal converter that can convert most process signals into a potentiometer output. The potentiometer consists of a series of true resistors that can be switched with 1 in 255 (8 bit) resolution.

Typical applications:

- Replace mechanical pot used for control of existing machinery;
- Automatic control of gain or offset in instrumentation;
- Provide programmable adjustment for Delays, Filters or Time Constants.

The ATP168 provides true 3-way galvanic isolation up to 2000V rms between various input signal types to potentiometer output to power supply. Connection can be made as a 3-wire pot or 2-wire variable resistor.

The output signal level is indicated by a green LED on the front of the module, giving a clear indication of module function, signal presence and loop condition for current outputs. Various power supply choices are available ranging from 240Vac down to 8dc. All provide power isolation and surge protection.



General Specifications

Size:	52 W x 70 H x 110 D (mm).
Housing material:	ABS.
Mounting:	DIN-Rail, gear plate.
Termination:	Screw terminals with covers.
Protection class:	IP40.
Weight:	0.370 kg.
Accuracy:	0.5% of span.
Front 'OFFS' adjust:	±20% typical
Front 'SPAN' adjust:	±20% typical
Integral non-linearity:	±1 LSB outputs less than 1k have reduced linearity.
Repeatability:	0.1% of span.
Response time:	0.5 sec for T90 standard 0.05 seconds selectable 5 milliseconds selectable.
Standard Input Impedance:	51Ω (20mA/10mA range). 1kΩ (1mA range). 2M7Ω (10V/5V range). 560kΩ (2V/1V range).
Temperature effect:	0.025% per °C.
Operating temp. range:	-10...-60°C.
Storage temp. range:	-20...+70°C.
Input/output isolation:	>2kV rms.
Power requirements:	3W.
Electromagnetic compatibility:	Complies with AS/NZS 4251.1 (EN 50081.1)
Resolution:	1 in 255 (8 bit) – 0.4%
Maximum applied voltage:	24Vdc or ac peak to 100kHz.
Maximum load:	not exceeding 100mA
Typical min impedance of wiper to end:	50Ω.

Block Diagram

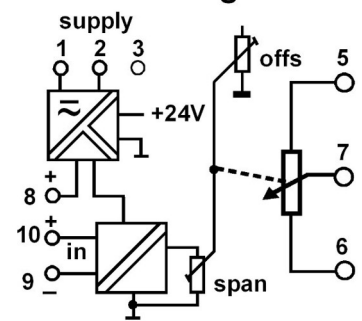

For input / output combinations refer to TYPE NO. DESIGNATION overleaf.

TYPE NO. DESIGNATION

Power Supply:

- 1 = 90-280Vac 50/60Hz (65-280Vdc). *) 6 = 8 - 60Vdc.
 *) 3 = 16-48Vac 50/60Hz (10-60Vdc)

Input:

- 01 = Process link table 1.
 *) 02 = Millivolt link table 2.
 *) 03 = RTD.
 *) 04 = Thermocouple.
 *) 05 = Frequency. Calibration range 0 - 10Hz...0 - 5kHz (Sine, Triangle)
 Sensitivity: 200mVpp. (70mVrms) min. 22Vpp. max (Square, Pulse).
 *) 06 = Pulse input from NAMUR proximity sensor or passive device (contact, open collector).
 Auxiliary supply of 8Vdc at terminal 8, other data as option 05.
 *) 07 = Bipolar / millivolt. ($\pm 0.5mV$ to $\pm 2kV$ bipolar) (1mV to 2kV unipolar).
 It may be more cost effective to use an alternate range.
 *) 08 = Resistance (constant current excitation).
 *) 09 = Potentiometer 3W voltage excited.

Specify type of sensor and calibration details.

Potentiometer:

- | | | |
|---------|----------|---|
| 1 = 1k | 5 = 20k | *) 9 = 73 to 201R, Cal: ~ 80.3 to 194.1 Ohm |
| 2 = 2k | 6 = 50k | A = 470R |
| 3 = 5k | 7 = 100k | |
| 4 = 10k | 8 = 200k | Potentiometer values less than 1k have reduced linearity. |

Connection:

- 2 = 2 wire *) 3 = 3 wire

Options:

- 00 = None. *) 08 = Customised response time.

Process link table 1 SW1

Input	1	2	3	4	5	6	7	8
4-20mA		X	X	X				X
0-1mA	X		X	X			X	
0-10mA		X	X	X	X		X	
0-20mA		X	X	X			X	
0-1V			X	X			X	
0-2V			X				X	
0-5V				X			X	
1-5V				X				X
0-10V							X	

Millivolt link table 2 SW1

Input	1	2	3	4	5	6	7	8
0-20mV			X	X	X	X	X	
0-40mV			X	X	X			
0-50mV			X	X	X		X	
0-60mV			X	X		X		
0-75mV			X	X		X	X	
0-100mV			X	X			X	
0-150mV			X		X		X	
0-200mV			X				X	
0-250mV				X	X		X	
0-500mV				X			X	
0-750mV					X		X	
0-1000mV							X	

Response Time Table 3 SW1

Response time	9	10
5msec		
50msec	X	
500msec		X

To change ranges:

- 1) Disconnect power to unit.
- 2) Unclip housing lid and withdraw unit from housing.
- 3) Set the coding plugs as required.
- 4) Reassemble unit and connect power.
- 5) Adjust "span" and "offs" pots to re calibrate.
- 6) Change the label information to the new input/output values.

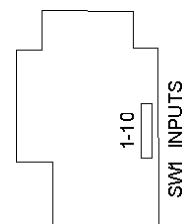

Factory default range: 4-20mA input 0.5 sec Response.

*) = Price Extra.

In the interest of development and improvement, APCS reserve the right to amend, without notice, details contained in this publication. APCS will accept no legal liability for any errors, omissions or amendments.