

DTA137 Optional Input 17 - Load Cell

This procedure applies to the C201 PCB.

Set-up Procedure

1. Verify connections and power up.
2. With load-cell connected measure the excitation voltage on terminals 7 and 8, adjust in accordance with load cell specifications using "EXT" adjustment.
3. Measure the offset signal by using the 2mm test socket with reference to terminal 7. Adjust this signal to be 0V ±0.1V via the "TARE" adjustment.
4. Apply full load to load-cell. The signal on the 2mm test socket should rise to approximately 2Vdc.
5. Adjust the CH1 trip potentiometer, so the relay contact (terminals 3 and 4) closes at the required input.
6. Adjust the CH2 trip potentiometer, so the relay contact (terminals 5 and 6) closes at the required input.

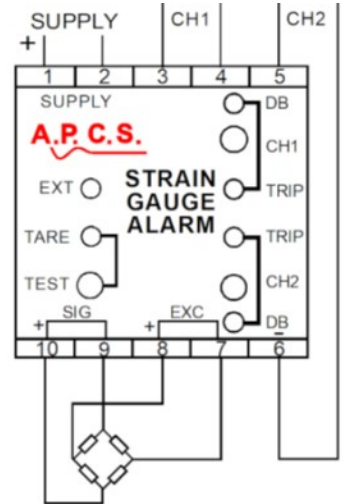

Complete Span Re-scale

1. For a complete rescale operation on the input, it is essential to remove the unit from the housing and separate the function board from the motherboard by removing the screw in the centre.
2. Select jumper positions on the range selector from the table below for the desired mV input.
3. Then follow 'Set-up Procedure' above.

Input	JP1 Setting
0 - 1mV	1
0 - 2 mV	2
0 - 3 mV	1,2
0 - 5mV	3
0 - 7 mV	2,3
0 - 10 mV	4
0 - 12mV	2,4
0 - 15 mV	3,4
0 - 20 mV	5
0 - 25mV	3,5
0 - 30 mV	4,5
0 - 50 mV	6
0 - 60 mV	4,6
Cal	7

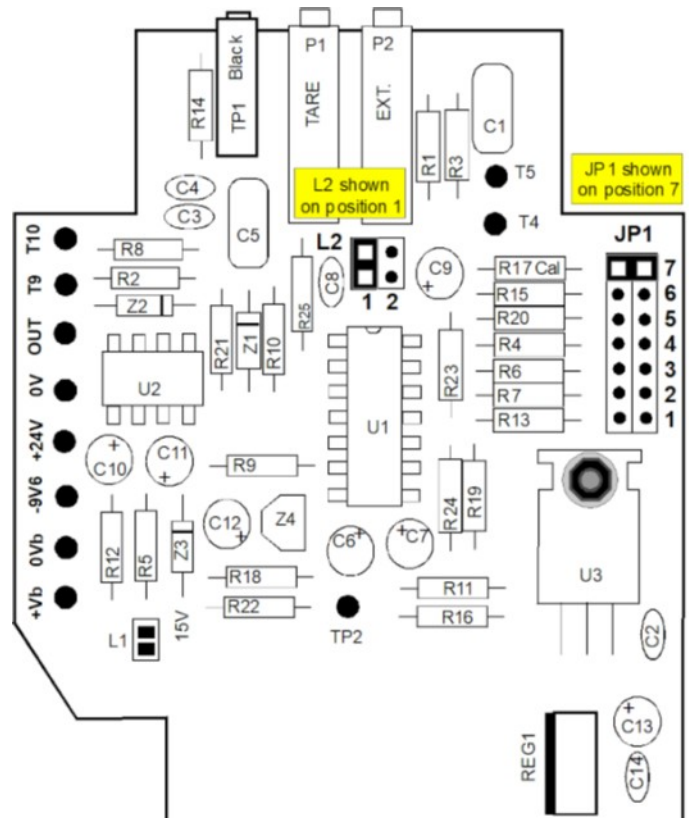

Notes

1. JP1 position 7 is a user-defined range that is factory installed if an input between 60 and 200mV was specified when ordering.
2. If the input span ordered is above 200mV all settings for JP1 should not be altered, the input cannot be re-scaled. The set-up procedure above still applies.

Input / Output Response

L2 is used to set the response time. The fastest response time (5ms) is set by a component on the base alarm card. If a slow response time was ordered then these links would have no effect however for fast response times the links can still be used to slow the response to 50 or 500ms.

500ms	Shunt position 2 of L2.
50ms	Shunt position 1 of L2.
5ms	Remove both shunts.

In the interest of development and improvement, APCS reserve the right to amend, without notice, details contained in this publication. APCS will accept no legal liability for any errors, omissions or amendments.